

Inside the ACB Turbo Bearing: Built for Performance

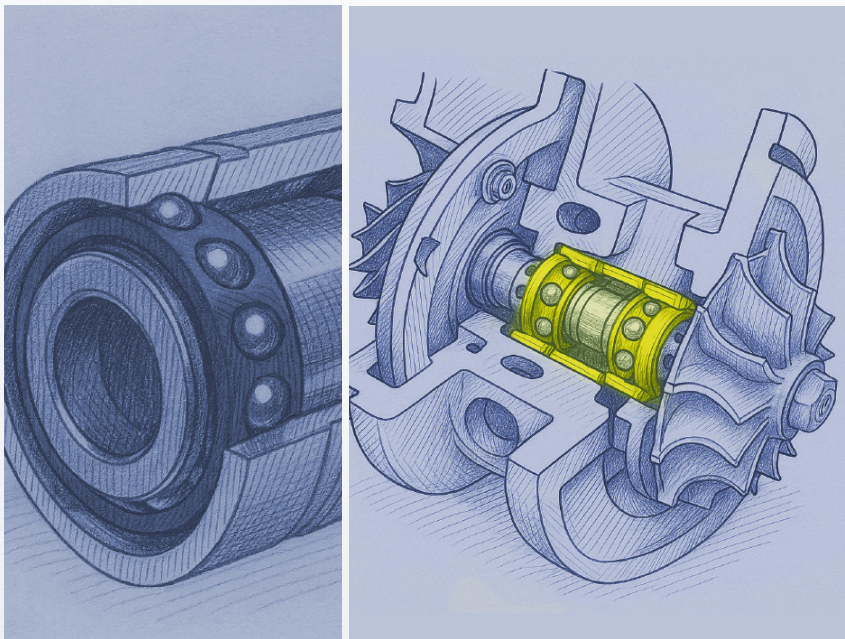
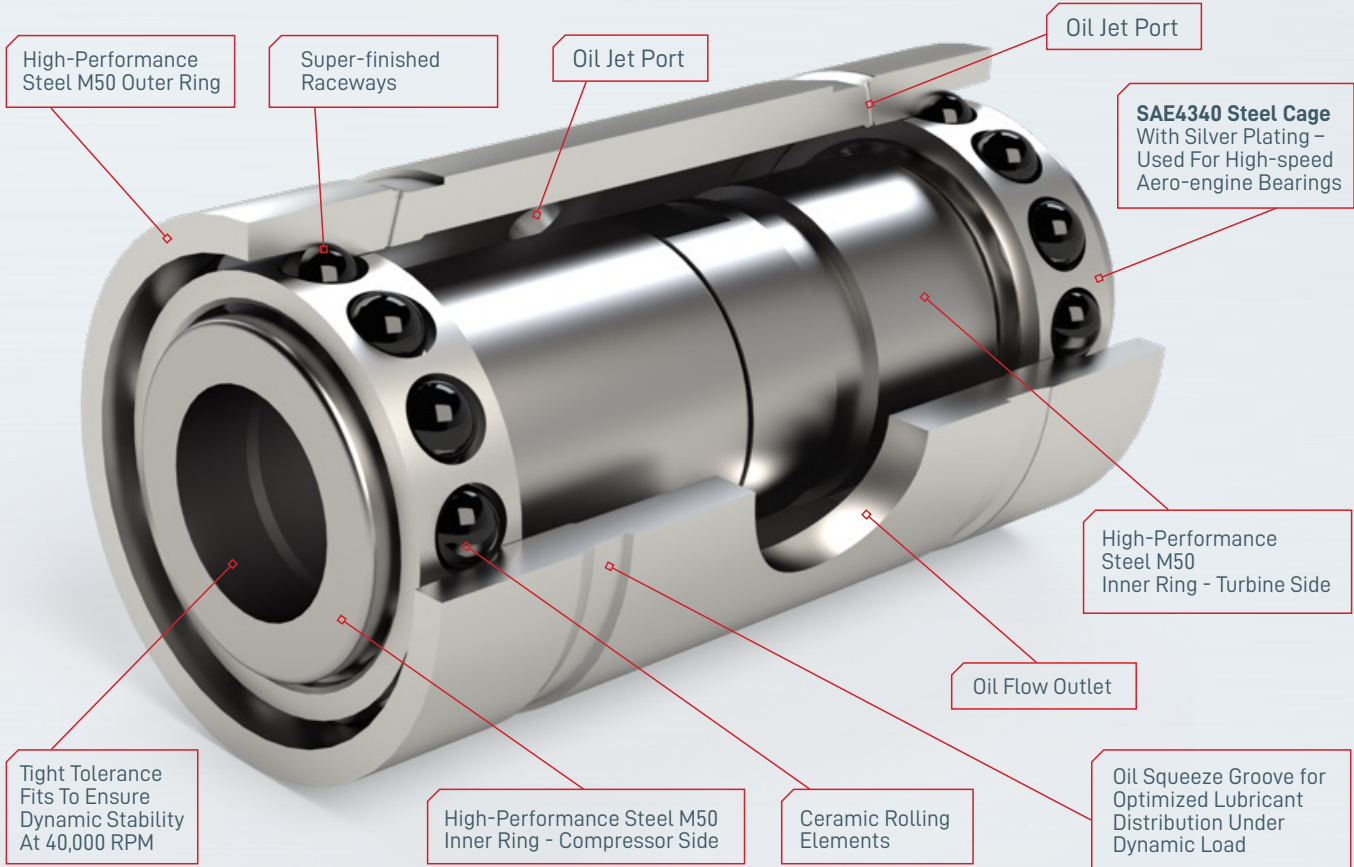

Turbo Compressor Sketch

ABS & ACB: From Reverse Engineering to Validated Performance

When OEM support is no longer available, operators need more than a replacement component—they need a solution they can trust. Through ACB Custom Bearings, ABS transformed a critical obsolescence challenge into a fully engineered bearing solution designed for the demanding conditions of high-altitude mining.

Combining advanced materials, precision manufacturing, and application-specific validation, the result is a reliable, fully interchangeable bearing that helps operators reduce risk, extend service life, and maintain equipment availability.